



Compton College Student Housing

1111 E. Artesia Blvd., Compton, CA 90221



Appliance Cutsheets

December 12, 2023



TABLE OF CONTENTS

ID	MODEL	DESCRIPTION
DW2	GE - GLDT690JBB	DISHWASHER - RESIDENT DIRECTOR UNIT
FR1	Whirlpool - WRS312SNHB	REFRIGERATOR - UNITS
FR2	Whirlpool - WRS315SNHM	REFRIGERATOR - COMMON KITCHEN
HO1	Summit ADAH1630B	UNDER CABINET HOOD - remote switch
HO2	Summit SEH6624CADA	PYRAMID CHIMNEY HOOD - remote switch
HO3	GE - JW5301FJDS	PYRAMID CHIMNEY HOOD
MV1	GE - JES1072DMBB	MICROWAVE - Units
MV2	FRIGIDARE - GMBS3068AF	BUILT-IN MICROWAVE 2.2 Cu. Ft.
RG1	GE - JD630DFBB	30" DROP-IN RANGE OVEN - Units
RG2	GE - JD630SFSS	DROP-IN RANGE OVEN - Common Kitchens
TR1	FRIGIDARE - PMTK3080AF	BUILT-IN MICROWAVE TRIM
WD1	SPEED QUEEN - STENYFSP176TW01	WASHER/DRYER STACKED
WD3	SPEED QUEEN - SFNNYASP116TW01	WASHER FRONT LOADING (ADA)
WD4	SPEED QUEEN - SSENYAGS176TW01	DRYER STACKED
	Element ELIM08A	LOCKABLE PACKAGE CONCIERGE
	Element ELIM10A	LOCKABLE PACKAGE CONCIERGE
	Element ELIK11A-PC	LOCKABLE PACKAGE CONCIERGE
	Element ELIM16A	LOCKABLE PACKAGE CONCIERGE
	Florence 10 high 4C10D-18	Mailbox

GLDT690J/GLDT696J

GE® Stainless Steel Interior Dishwasher with Hidden Controls

DIMENSIONS AND INSTALLATION INFORMATION (IN INCHES)

ELECTRICAL RATING

Voltage AC.....	120
Hertz.....	60
Total connected load amperage.....	6.7
Calrod® heater watts max.....	650

For use on adequately wired 120-volt, 15-amp circuit having 2-wire service with a separate ground wire. This appliance must be grounded for safe operation.

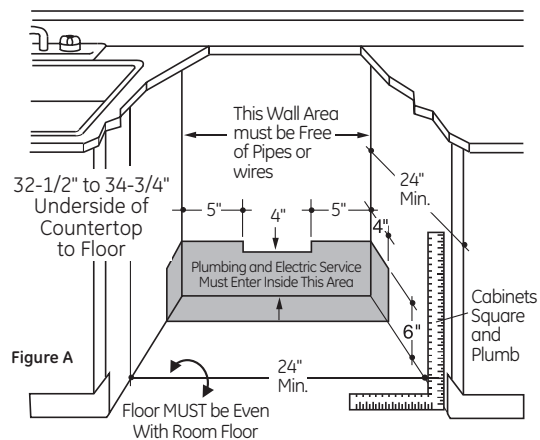

- The rough cabinet opening must be at least 24" deep, 24" wide and approximately 32-1/2" to 34-3/4" high from floor to underside of the countertop.

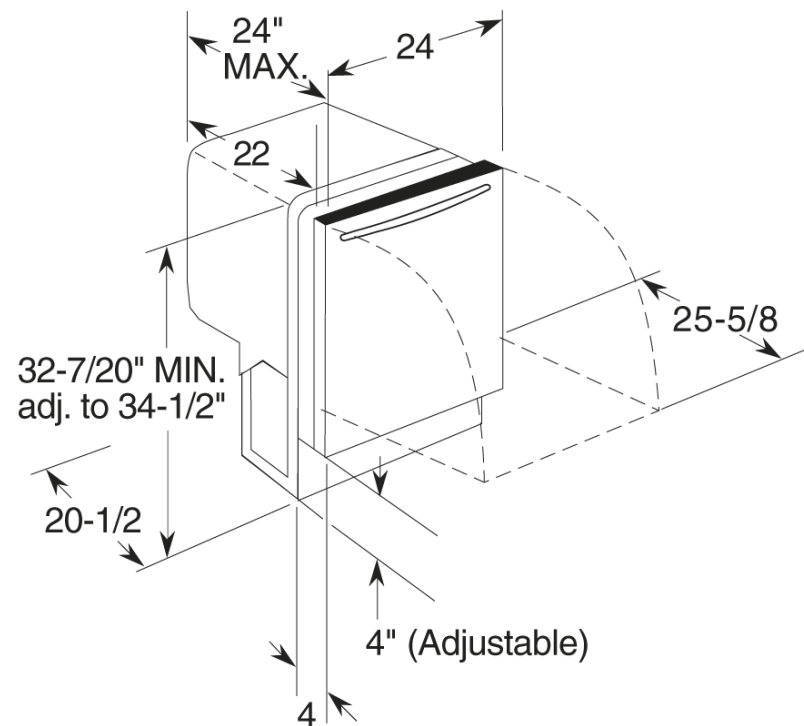

For answers to your Monogram, GE Café™ Series, GE Profile™ Series or GE Appliances product questions, visit our website at geappliances.com or call GE Answer Center® Service, 800.626.2000.



Listed by Underwriters Laboratories



As an ENERGY STAR® partner, GE has determined that this product meets the ENERGY STAR guidelines for energy efficiency.

GLDT690J/GLDT696J

GE® Stainless Steel Interior Dishwasher with Hidden Controls

FEATURES AND BENEFITS

Bright annealed stainless steel interior - Attractive interior provides long-lasting durability

Low profile installation capable - Great for raised sub-floors and 34" countertop heights

Gray racks - Long-lasting, durable racks resist rusting, chipping and peeling

Two utility shelves in upper rack with Stem Safe - Conveniently flip down to handle tall items and protect stemware

2-digit countdown display with 1-24 hour Delay Start - Wash dishes at your convenience and monitor the progress

Audible end-of-cycle signal - Alert signals when cycle is complete

5 wash levels - Eliminates the central wash tower to accommodate more items

ADA-compliant - Dishwasher design allows for simple operation and easy access

ENERGY STAR® qualified - Meets or exceeds federal guidelines for energy efficiency for year-round energy and money savings

Model GLDT690JWW - White on white

Model GLDT690JBB - Black on black

Model GLDT696JSS - Stainless steel (shown)

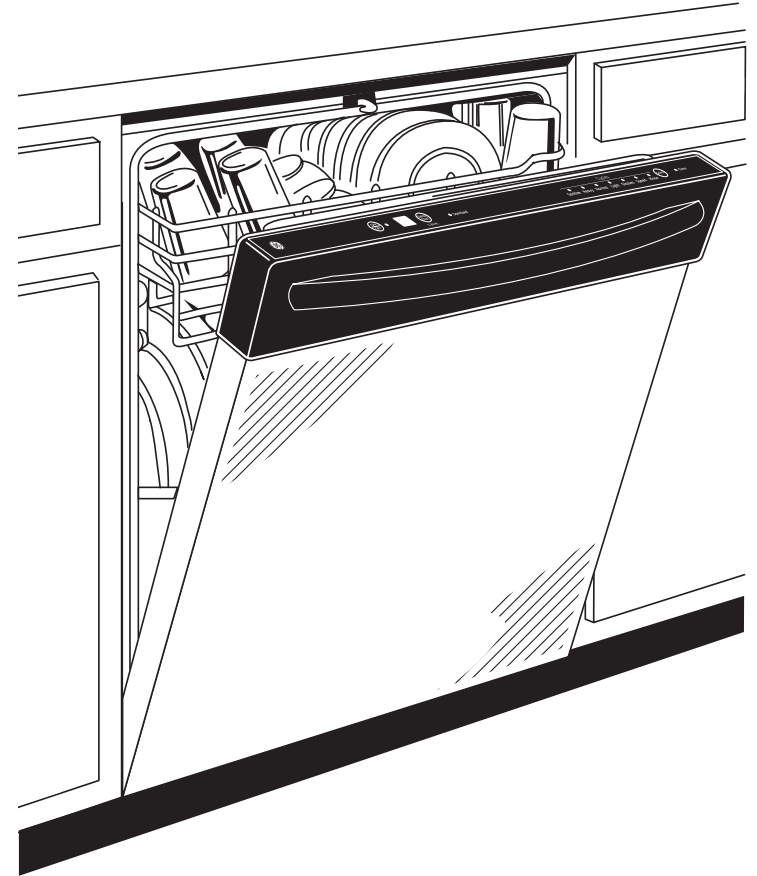

As an ENERGY STAR® partner, GE has determined that this product meets the ENERGY STAR guidelines for energy efficiency.



22 cu. ft. Side-by-Side Refrigerator

WRS312SNH



Monochromatic Stainless Steel
WRS312SNHM

Also available in:

- White **WRS312SNHW**
- Black **WRS312SNHB**

Capacity

Total Capacity	22 cu. ft.
Refrigerator Capacity	15 cu. ft.
Freezer Capacity	7 cu. ft.

General Features & Properties

Electronic Temperature Controls

Optional Icemaker

Frameless Glass Shelves

Adaptive Defrost

Humidity-Controlled Crispers

#1 Selling Appliance Brand in the U.S.A.*

Electrical Details

Amps	7.2
Volts	110

Technical Details

Refrigerator Type	Side-by-Side
Number of Doors	2
Number of Interior Refrigerator Shelves	4
Number of Refrigerator Door Bins	2 Fixed, 3 Adjustable
Number of Interior Freezer Shelves	4
Number of Freezer Door Bins	4 Fixed
Lighting Type	LED
Ice Maker	Optional
Ice Maker Location	Freezer
Dispenser Type	No Dispenser

Dimensions

Product Dimensions (H x W x D)	66-5/8" x 32-3/4" x 33-5/8"
Depth with Door Open 90°	49-5/16"
Cutout Dimensions	Allow extra 1/2" on sides and top Allow extra 1" on rear

Reference Material

[Dimension Guide](#)

[Install Guide](#)

[Energy Guide](#)

[Warranty](#)

Key Features & Benefits

Adjustable Gallon Door Bins

Move these adjustable bins anywhere in the door for increased loading flexibility when and where you need it.

LED Interior Lighting

Keep food looking as good as it tastes. Light is cast inside the refrigerator so food looks like it's supposed to.

Hidden Hinges

Get a seamless look with door hinges that stay out of sight.

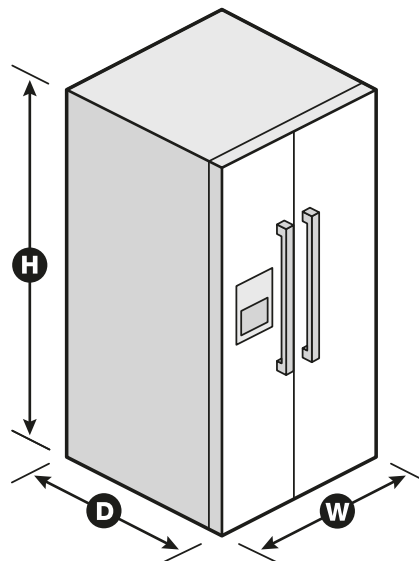



25 cu. ft. Side-by-Side Refrigerator

WRS315SNH



Monochromatic Stainless Steel
WRS315SNHM

Also available in:

- White **WRS315SNHW**
- Black **WRS315SNHB**

Capacity

Total Capacity	25 cu. ft.
Refrigerator Capacity	15 cu. ft.
Freezer Capacity	10 cu. ft.

General Features & Properties

Electronic Temperature Controls

Optional Icemaker

Frameless Glass Shelves

Adaptive Defrost

Humidity-Controlled Crispers

#1 Selling Appliance Brand in the U.S.A.*

Electrical Details

Amps	15 or 20
Volts	115

Technical Details

Refrigerator Type	Side-by-Side
Number of Doors	2
Number of Interior Refrigerator Shelves	4
Number of Refrigerator Door Bins	2 Fixed, 3 Adjustable
Number of Interior Freezer Shelves	4
Number of Freezer Door Bins	4 Fixed
Lighting Type	LED
Ice Maker	Optional
Ice Maker Location	Freezer
Dispenser Type	No Dispenser

Dimensions

Product Dimensions (H x W x D)	69-5/8" x 35-7/8" x 33-5/8"
Depth with Door Open 90°	49-5/16"
Cutout Dimensions	Allow extra 1/2" on sides and top Allow extra 1" on rear

Reference Material

[Dimension Guide](#)

[Install Guide](#)

[Energy Guide](#)

[Warranty](#)

Key Features & Benefits

Adjustable Gallon Door Bins

Move these adjustable bins anywhere in the door for increased loading flexibility when and where you need it.

LED Interior Lighting

Keep food looking as good as it tastes. Light is cast inside the refrigerator so food looks like it's supposed to.

Hidden Hinges

Get a seamless look with door hinges that stay out of sight.

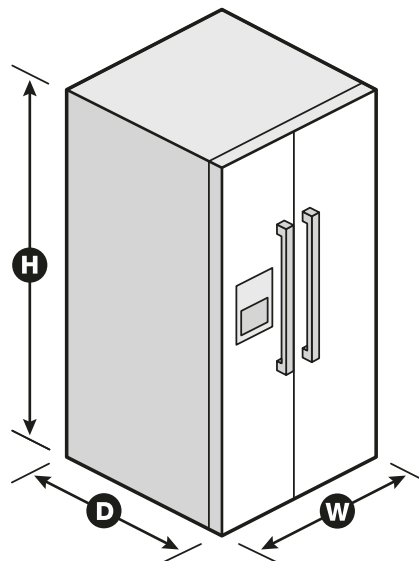



ADAH1630B



5" x 30" x 18" (H x W x D)

30 inch wide ADA compliant convertible range hood for ducted or ductless use in black with remote wall switch

Highlights:

ADA compliant design allows you to control the hood from a wall light switch for easier accessibility

30" wide range hood matches slim apartment sized ranges and cooktops

Convertible from top or rear venting into non-vented recirculating mode

Product Features:

ADA compliant design	Hood is wired to run off a wall switch for improved accessibility, with a remote terminal block included
30" width	Designed to fit over commonly sized ranges and cooktops
Convertible design	Use top or rear venting or convert into non-vented recirculating mode
Black finish	Stainless steel and white range hoods also available in this size and series
Two-speed fan	High and low setting gives you the right amount of power for most general cooking applications
Dishwasher-safe aluminum filter	Removable mesh filter with solid construction and easy cleanability
Charcoal liner	Filter includes a charcoal liner for better absorption of grease and odors
Switchable light option	Unit can accept a light bulb (max 40W) with the switch included on the remote terminal block. Bulb is not included.
Made in the USA	Solidly constructed for years of use



ADAH1630B Specifications:

Overview	
Height of Cabinet	5.0" (13 cm)
Width	30.0" (76 cm)
Depth	18.0" (46 cm)
Cabinet	Black
US Electrical Safety	UL
Weight	14.0 lbs. (6 kg)
Shipping Weight	15.0 lbs. (7 kg)
Parts & Labor Warranty	1 Year
UPC	761101064215
Range Hood	
Installation	Under Cabinet
Venting	Convertible
Number of Fan Speeds	2
Maximum Air Movement	160.0 CFM



SEH6624CADA



30" x 23.5" x 21.63" (H x W x D)

24 inch ADA compliant European wall-mounted range hood in stainless steel with remote wall switch

Highlights:

ADA compliant design allows you to control the hood from a wall light switch for easier accessibility

Designed and manufactured in Spain

Elegant style in brushed stainless steel

Product Features:

ADA compliant design	Control panel comes on a remote terminal block to be installed according to ADA compliant guidelines for improved accessibility (some assembly required)
Stainless steel construction	Quality material with an elegant look in brushed stainless steel
600 CFM blower	Professional European motor is preinstalled for easy use
Convertible with filter	Designed for ducted use, this range hood can be used in recirculating (ductless) mode when you order SEHCFISL charcoal filter set
Two aluminum cassette filters	Dishwasher safe filters offer wide filtration area for better ventilation
Timer function	Set the unit to ventilate for a 15 minute interval that automatically turns off when complete
Two 40W lights	Includes two preinstalled incandescent bulbs
Three-speed fan	Offers more options for ventilation
European made	Designed and manufactured in Spain with all UL-Listed components



SEH6624CADA Specifications:

Overview	
Height of Cabinet	30.0" (76 cm)
Width	23.5" (60 cm)
Depth	21.63" (55 cm)
Cabinet	Stainless Steel
US Electrical Safety	UL
Canadian Electrical Safety	ULC
Amps	5.0
Voltage/Frequency	115 V AC/60 Hz
Weight	29.0 lbs. (13 kg)
Shipping Weight	52.0 lbs. (24 kg)
Parts & Labor Warranty	1 Year
UPC	761101063591
Range Hood	
Installation	Wall-Mounted
Venting	Convertible w/ Filter Set
Controls	Slide
Light	Yes
Number of Lights	2
Light Type	Incandescent
Number of Fan Speeds	3
Maximum Air Movement	600.0 CFM
Minimum Height	29.0" (74 cm)
Maximum Height	41.0" (104 cm)

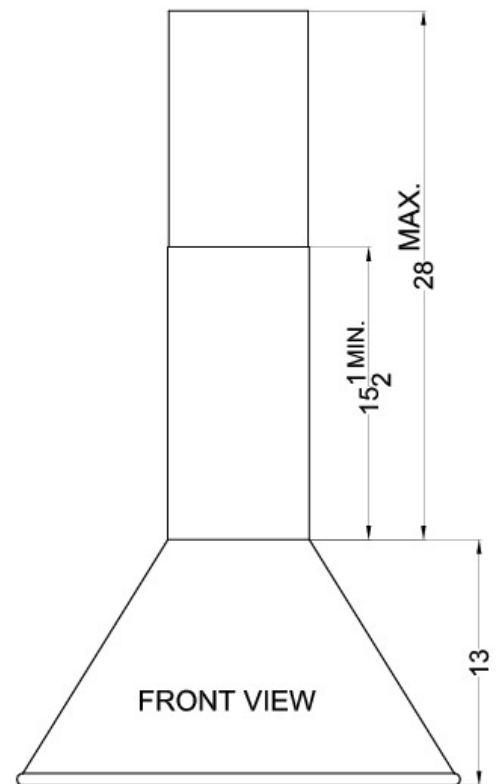
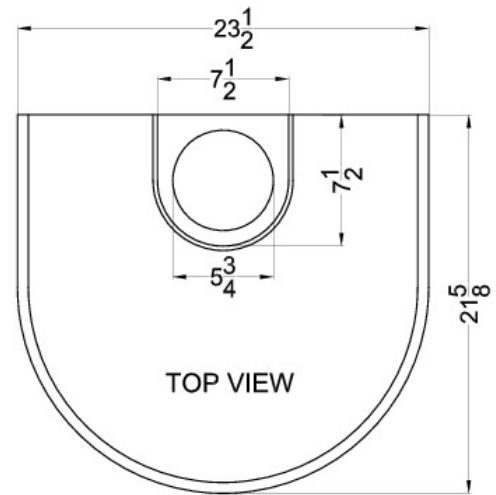

JVW5301SJ/EJ/BJ/FJ

GE® 30" Wall-Mount Pyramid Chimney Hood

DIMENSIONS AND INSTALLATION INFORMATION (IN INCHES)

INSTALLATION INFORMATION:

Before installing, consult Use & Care/installation instructions packed with product for current dimensional data.

OPTIONAL ACCESSORIES

UXDC72SJSS/FJDS/BJTS – 9(ft.) Ceiling Duct Cover Kit
 UXDC53SJSS/EJES/BJTS/FJDS – 10(ft.) Ceiling Duct Cover Kit

For 30" distance from counter to hood:

Below 8'-4" ceiling height – no duct cover required

8'-4" – 9'-6" ceiling height – use UXDC72SJSS/FJDS/BJTS

Above 9'-7" ceiling height – use UXDC53SJSS/EJES/BJTS/FJDS

Refer to Installation Instructions for exact specifications

UXRC70 – Remote Control

JXCF72 – Charcoal Filter (needed if used in recirculation mode)

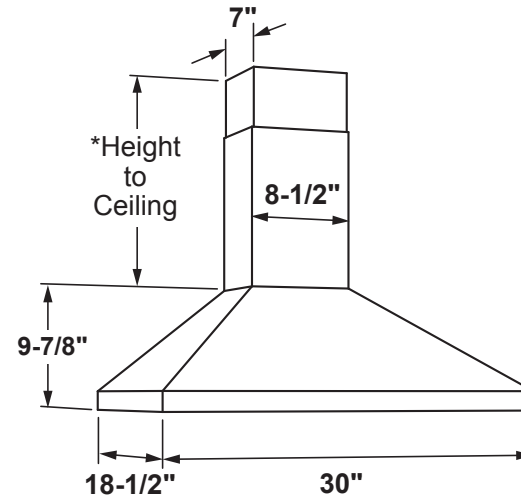

30" Models Require a 30"-Wide Opening

*The supplied duct cover fits 7'-4" to 9'-0" ceiling heights (10' with optional high ceiling kit UXDC53)

AMP RATING	
120V	2.5

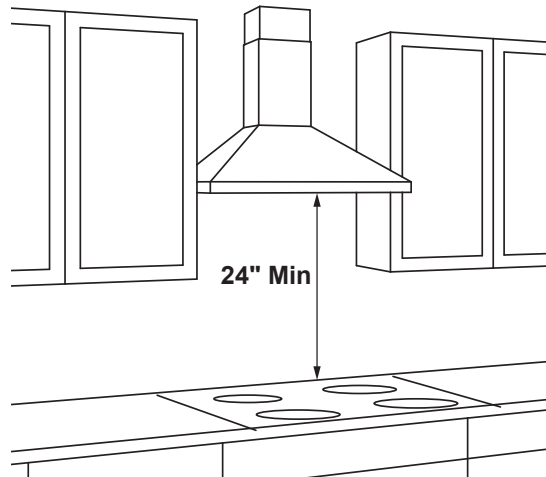

The vent hood must be installed 24" min. above the cooking surface. For optimal performance, installing the hood more than 38" above the cooking surface is not recommended. The hood installation height above the cooking surface depends upon ceiling height. The telescopic duct cover conceals the ductwork running from the top of the hood to the ceiling.

NOTE: Installation height should be measured from the cooking surface to the lowest part of the hood. This hood may be installed onto a wall and vented to the outdoors, or it can be installed for recirculating operation. Parts for recirculating operation are supplied with the hood. However, when installed for recirculating operation, the optional charcoal Filter JXCF72 will need to be purchased separately.



For answers to your GE Profile™ Series or GE Appliances product questions, visit our website at geappliances.com or call GE Answer Center® Service, 800.626.2000.



Specification Revised 01/20

JVW5301SJ/EJ/BJ/FJ

GE® 30" Wall-Mount Pyramid Chimney Hood

FEATURES AND BENEFITS

350-CFM venting system with boost – Effectively remove smoke, grease, odor and moisture

Electronic backlit controls – Add a sophisticated look with this up-front, easy-to-use display

Dual halogen cooktop light – Enjoy better visibility with a brightly lit cooktop and surrounding surface

Night light – Keep a dim light on for visibility at all hours

Convertible venting options – Select recirculating or external venting

Remote control option – Control your ventilation lighting and fan speed from anywhere in the kitchen

Model JVW5301SJSS – Stainless steel

Model JVW5301EJES – Slate

Model JVW5301BJTS – Black stainless

Model JVW5301FJDS – Black slate

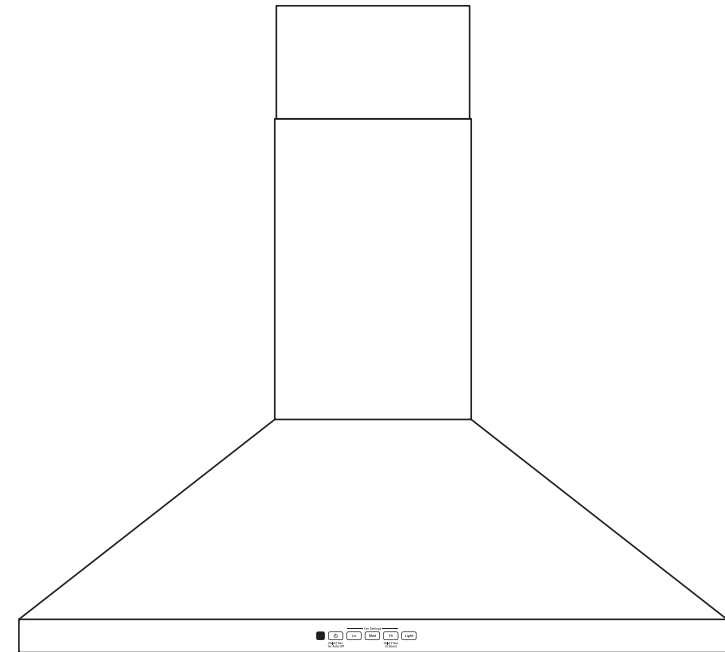

JES1072DM/SH

GE® 0.7 Cu. Ft. Capacity Countertop Microwave Oven

DIMENSIONS AND INSTALLATION INFORMATION (IN INCHES)

EXTERIOR DIMENSIONS* (IN INCHES)	
H x W x D	10-3/16 x 17-5/16 x 12-3/4

*Height includes feet. Depth does not include handle

Note: This unit designed to be placed on countertop.

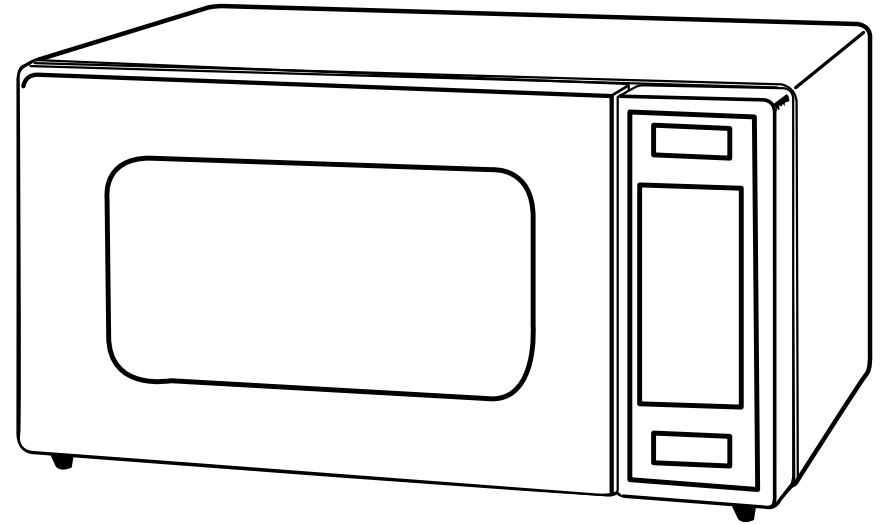

For answers to your Monogram, GE Café™ Series, GE Profile™ Series or GE Appliances product questions, visit our website at geappliances.com or call GE Answer Center® Service, 800.626.2000.



Specification Created 12/17

JES1072DM/SH

GE® 0.7 Cu. Ft. Capacity Countertop Microwave Oven

FEATURES AND BENEFITS

0.7 cu. ft. capacity - 700 Watts (IEC-705 test procedure)

Convenience cooking controls - Operating made quick and easy

Stainless steel - Both stylish and easy to clean

Auto & time defrost - Defrosting time and power level are programmed automatically or manually for optimal results

Turntable - Rotates food throughout cycle

Control lockout - Helps prevent accidental activation

Kitchen timer - Minute timer helps keep you on track

Model JES1072SHSS - Stainless steel

Model JES1072DMBB - Black

Model JES1072DMWW - White

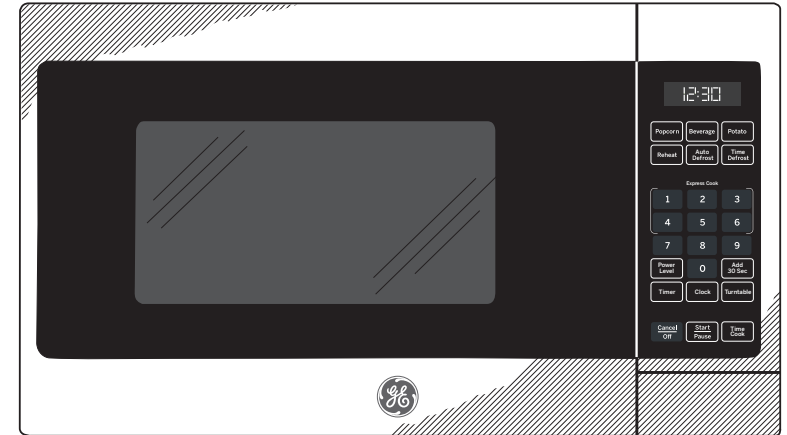

For answers to your Monogram, GE Café™ Series, GE Profile™ Series or GE Appliances product questions, visit our website at geappliances.com or call GE Answer Center® Service, 800.626.2000.

2.2 Cu. Ft. Built-In Microwave

Built-In Microwave

Available Products: GMBS3068AD, GMBS3068AF

Available Colors: Black Stainless Steel, Stainless Steel

Version: 09/22



Install Trim Kit Required. Multiple sizes available.

Product Specifications

Cooking Controls

Cooking Power	1100 Watts
Number of Power Levels	10

Microwave Control Features

+ 10 Seconds	Yes - One Touch
+ 30 Seconds	Yes - One Touch
Quick Start	Yes

Exterior

Door Swing	Side-Swing Door
------------	-----------------

Dimensions and Volume

Height	13 5/8"
Width	24 7/16"
Depth	19 5/8"
Microwave Interior Height	11 1/4"
Microwave Interior Width	17 7/8"
Microwave Interior Depth	19 1/8"
Microwave Capacity	2.2 Cu. Ft.

Installation

Power Supply Connection Location	Right Top
----------------------------------	-----------

Safety Certifications and Approvals

UL Listed	Yes
cUL Listed	Yes

Microwave Cooking

Auto Cook	Yes
Bacon	Yes
Beverage	Yes
Defrost	Yes
Melt / Soften	Yes
Popcorn	Yes
Potato	Yes
Reheat	Yes
Sensor Cooking	Yes
Sensor Reheat	Yes
Veggies	Yes

Additional Settings

Child Lock	Yes
Demo On / Off	Yes
Language Options	English and French
Setting Turntable On / Off	No
Setting Weight Lb / Kg	Yes
Timer On / Off	Yes
Volume # of Settings	4 (Includes Off)

Internal Specifications

Interior Color	White
Interior Light Quantity	1
Interior Light Type	LED
Interior Light Wattage	1.2 Watts
Turntable Diameter	16 1/2"
Turntable Material	Glass

Electrical Specifications

Voltage Rating	120 V
Watts @ 120 Volts	1,100 Watts

General Specifications

Prop 65 Label	Yes
Warranty - Labor	1 Year
Warranty - Parts	1 Year

Installation Diagram

CABINET OR WALL CUTOUT

Cutout Dimensions

Height (A)		
Minimum	16" 3/4	(42.5 cm)
Maximum	17"	(43.2 cm)
Width (B)		
Minimum	24 3/4"	(62.9 cm)
Maximum	25"	(63.5 cm)
Depth (C)		
Minimum	20"	(50.8 cm)

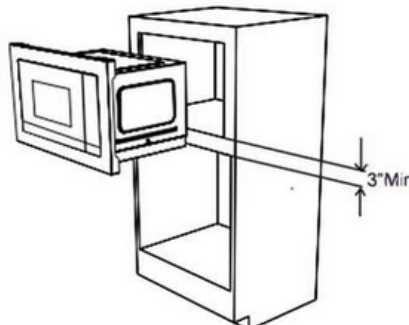

30"
TRIM KIT



30" STAINLESS TRIMKIT
(GMTK3068AF)

27"
TRIM KIT



27" STAINLESS TRIMKIT
(GMTK2768AF)

* MICROWAVE (GMBS3068AF) PICTURED ABOVE PAIRED WITH STAINLESS STEEL TRIM KIT (GMTK3068AF / GMTK2768AF)

* Trim Kit Sold Separately

30"
TRIM KIT



30" DARK STAINLESS TRIMKIT
(GMTK3068AD)

27"
TRIM KIT



27" DARK STAINLESS TRIMKIT
(GMTK2768AD)

* MICROWAVE (GMBS3068AD) PICTURED ABOVE PAIRED WITH BLACK STAINLESS STEEL TRIM KIT (GMTK3068AD / GMTK2768AD)

* Trim Kit Sold Separately

Model Number	Color	Description
GMBS3068AF	SS	Microwave
GMBS3068AD	Black SS	Microwave
GMTK3068AF	SS	* 30" trim kit
GMTK2768AF	SS	* 27" trim kit
GMTK3068AD	Black SS	* 30" trim kit
GMTK2768AD	Black SS	* 27" trim kit

* Trim Kit Sold Separately

Trim Kit Overall Dimensions		
	27"	30"
Height	18" (460.8 mm)	18" (460.8mm)
Width	27" (685.8mm)	30" (759mm)
Depth	1 3/5" (40.9mm)	1 3/5" (40.9mm)

JD630DF

GE® 30" Drop-In Electric Range

DIMENSIONS AND INSTALLATION INFORMATION (IN INCHES)

JUNCTION BOX LOCATION: Electric drop-ins are not approved for installation with a plug and receptacle. This range is supplied with a flexible conduit and must be hard wired to a junction box. See shaded area in drawing for location of junction box. Refer to installation instructions for more information.

IMPORTANT: 30" DROP-IN RANGES ARE DESIGNED TO HANG FROM THE COUNTERTOP. IT DOES NOT REST ON THE FLOOR. FOR INSTALLATION ALTERNATIVES, REFER TO INSTALLATION INSTRUCTIONS.

NOTE: This appliance has been approved for 0" spacing to adjacent surfaces above the cooktop. However, a 6" minimum spacing to surfaces less than 15" above the cooktop and adjacent cabinet is recommended to reduce exposure to steam, grease splatter and heat.

OPTIONAL KITS FOR DROP-IN ELECTRIC RANGES: (Available At Additional Cost)

REAR FILLER STRIP:

WB07T10680 - Black Filler Strip Assembly

INSTALLATION INFORMATION: Before installing, consult installation instructions for current dimensional data and additional requirements.

NOTE: Check local codes for required breaker size.

If you are using the Filler strip:

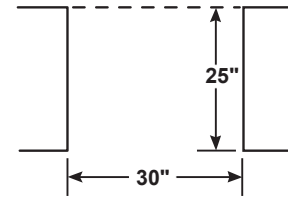

If you are NOT using the Filler strip:

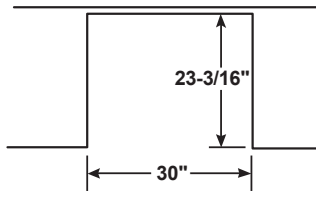

KW RATING	
240V	11.9
208V	8.9
BREAKER SIZE	
240V	40 Amps†
208V	40 Amps†

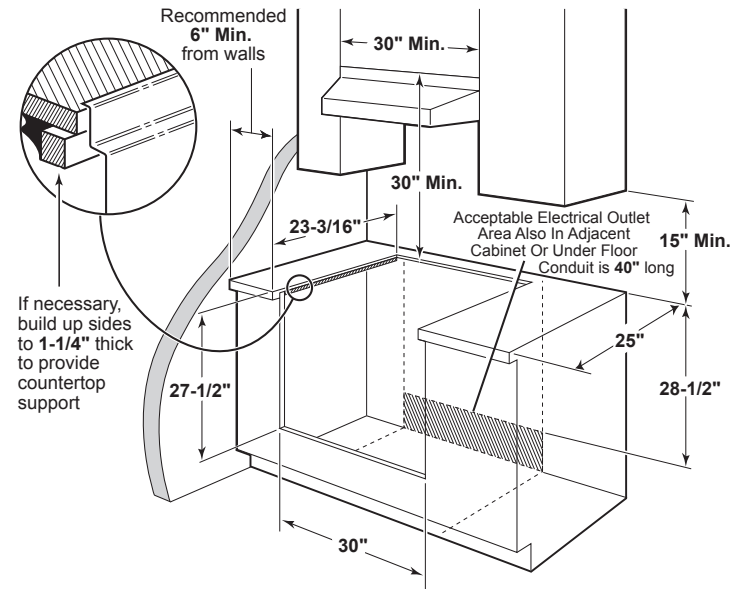

Above illustration intended for dimensional reference only. Refer to photograph for actual product appearance.

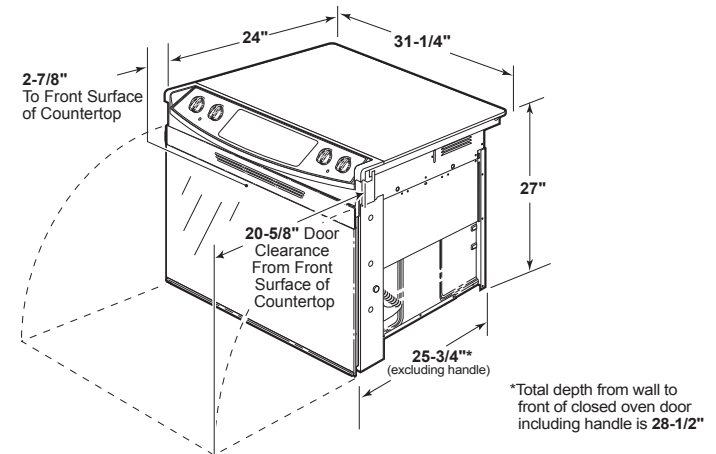

Dimension and installation information are shown in inches.



For answers to your Monogram, GE Café™ Series, GE Profile™ Series or GE Appliances product questions, visit our website at geappliances.com or call GE Answer Center® Service, 800.626.2000.



All GE ranges are equipped with an Anti-Tip device. The installation of this device is an important, required step in the installation of the range.



Listed by Underwriters Laboratories



JD630DF

GE® 30" Drop-In Electric Range

FEATURES AND BENEFITS

6"/9" Power Boil element – Produces rapid, powerful heat

Self-clean oven – Cleans the oven cavity without the need for scrubbing

Ceramic glass cooktop – Smooth cooktop easily wipes clean

Black gloss oven interior – Enjoy a clean and sleek appearance

Dual element bake – Upper and lower elements produce even heat and great results

Electronic oven controls – Electronic touch pads are easy to operate

Model JD630DFWW – White on white

Model JD630DFBB – Black on black



JD630SF

GE Appliances 30" Drop-In Electric Range

DIMENSIONS AND INSTALLATION INFORMATION (IN INCHES)

JUNCTION BOX LOCATION: Electric drop-ins are not approved for installation with a plug and receptacle. This range is supplied with a flexible conduit and must be hard wired to a junction box. See shaded area in drawing for location of junction box. Refer to installation instructions for more information.

IMPORTANT: 30" DROP-IN RANGES ARE DESIGNED TO HANG FROM THE COUNTERTOP. IT DOES NOT REST ON THE FLOOR. FOR INSTALLATION ALTERNATIVES, REFER TO INSTALLATION INSTRUCTIONS.

NOTE: This appliance has been approved for 0" spacing to adjacent surfaces above the cooktop. However, a 6" minimum spacing to surfaces less than 15" above the cooktop and adjacent cabinet is recommended to reduce exposure to steam, grease splatter and heat.

OPTIONAL KITS FOR DROP-IN ELECTRIC RANGES: (Available At Additional Cost)

REAR FILLER STRIP:
WB07T10680 – Black Filler Strip Assembly

INSTALLATION INFORMATION: Before installing, consult installation instructions for current dimensional data and additional requirements.

NOTE: Check local codes for required breaker size.

If you are using the Filler strip:

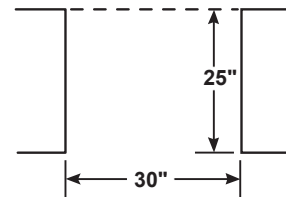

If you are NOT using the Filler strip:

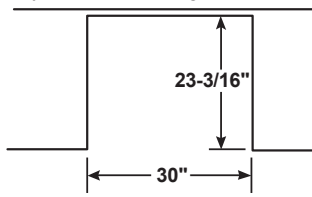

KW RATING	
240V	11.9
208V	8.9
BREAKER SIZE	
240V	40 Amps†
208V	40 Amps†

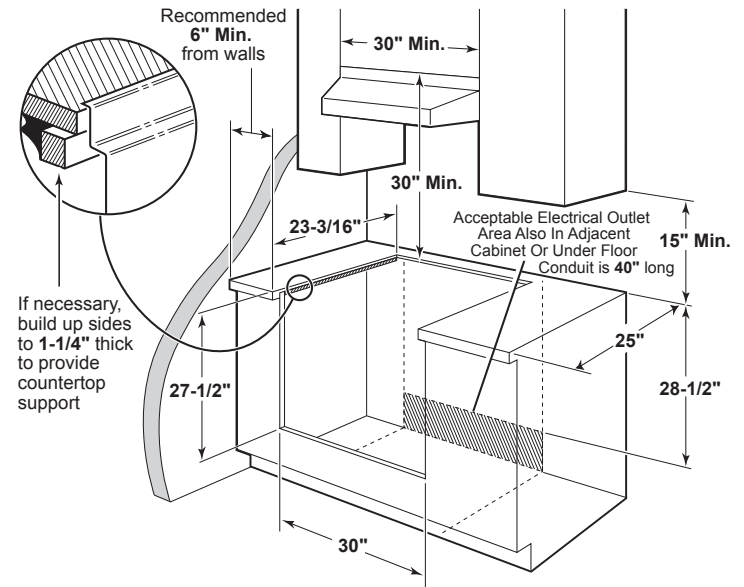

Above illustration intended for dimensional reference only. Refer to photograph for actual product appearance.

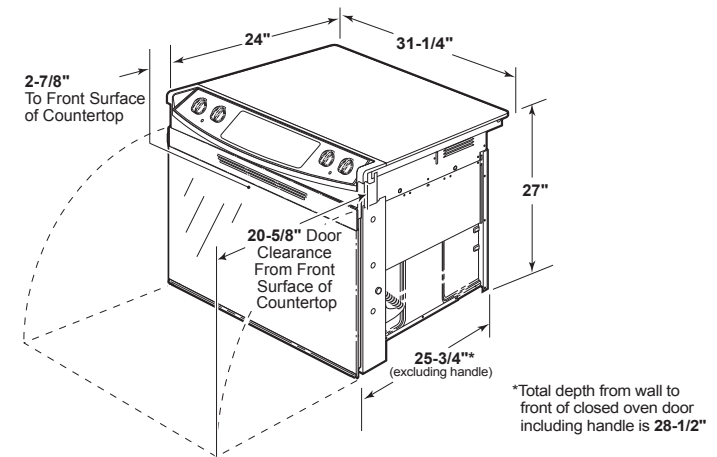

Dimension and installation information are shown in inches.



For answers to your Monogram, GE Café™ Series, GE Profile™ Series or GE Appliances product questions, visit our website at geappliances.com or call GE Answer Center® Service, 800.626.2000.



All GE ranges are equipped with an Anti-Tip device. The installation of this device is an important, required step in the installation of the range.



Listed by Underwriters Laboratories



JD630SF

GE Appliances 30" Drop-In Electric Range

FEATURES AND BENEFITS

6"/9" Power Boil element – Produces rapid, powerful heat

Self-clean oven – Cleans the oven cavity without the need for scrubbing

Ceramic glass cooktop – Smooth cooktop easily wipes clean

Black gloss oven interior – Enjoy a clean and sleek appearance

Dual element bake – Upper and lower elements produce even heat and great results

Electronic oven controls – Electronic touch pads are easy to operate

Model JD630SFSS – Stainless steel



Installation Instructions

Built-in Trim Kit

Model # GMTK3068AF GMTK2768AF GMTK3068AD
GMTK2768AD

BEFORE YOU BEGIN

- **IMPORTANT** – Save these instructions for local inspector's use.
- **IMPORTANT** – Observe all governing codes and ordinances.
- **Note to Installer** – Be sure to leave these instructions with the Consumer.
- **Note to Consumer** – Keep these instructions for future reference.
- **Skill level** - Installation of this appliance requires basic mechanical and electrical skills.
- Proper installation is the responsibility of the installer.
- Product failure due to improper installation is not covered under the Warranty.

Read these instructions completely and carefully.

- Please make sure the cabinet is level or vertical to front panel of cabinet before installation. Uneven cabinets may cause the trim kits to be noncoplanar with the door panels of microwave oven.
- Unplug the microwave oven before attempting installation of this kit.
- Because the kit includes metal parts, caution should be used in handling and installation to avoid the possibility of injury.
- Do not remove permanently affixed labels, warnings, or plates from the product. This may void the warranty.
- A statement shall be included in the instructions warning the user that the appliance must be disconnected from the source of supply before attempting the installation of the accessory, and that the accessory is intended for use only with an appliance that is marked to indicate such use.

FOR YOUR SAFETY:

WARNING – Before beginning the installation, switch power off at service panel and lock out to prevent being switched on accidentally. When the service cannot be locked, securely fasten a prominent warning device, such as a tag, to the service panel.

IMPORTANT - PLEASE READ AND FOLLOW

THIS BUILT-IN KIT IS DESIGNED FOR USE ONLY WITH ELECTROLUX MICROWAVE OVENS SPECIFYING BUILT-IN KIT

IMPORTANT:

Before installing the exhaust duct, confirm the floor is level. The level bubble should be equal distance from level guide lines.



QUESTIONS?

For customers in the United States call: 1-800-944-9044
For customers in Canada call: 1-800-265-8352 (English)
1-800-668-4606 ext.8199 (French)
Visit our Website at: www.frigidaire.com
READ CAREFULLY.
KEEP THESE INSTRUCTIONS.

PN: A06823528
September 2021

Installation Instructions

PARTS INCLUDED IN THE KIT

1. Front Frame Assembly- QTY 1
2. Exhaust Duct - QTY 1
 - Bottom Mounting Rail – QTY 2
3. Screw A - QTY 11+3 extra
4. Screw B - QTY 4 + 2 extra

CHOOSING A LOCATION FOR YOUR MICROWAVE OVEN IF BUILT-IN

Built-In Trim Kit allows for the installation of microwaves listed below to be built into a cabinet or wall by itself or over an electric wall oven*.

Model Number	Color	Description
GMBS3068AF	Easy Care SS	Microwave
GMBS3068AD	Black SS	Microwave
GMTK3068AF	Easy Care SS	30" Trim Kit
GMTK2768AF	Easy Care SS	27" Trim Kit
GMTK3068AD	Black SS	30" Trim Kit
GMTK2768AD	Black SS	27" Trim Kit

See Illustration 1 for proper location and when building in above a wall oven. Carefully follow both the wall oven installation instructions and Electrolux's Built-in Kit instructions. If building over a wall oven, be sure the clearance between the wall oven and the microwave oven is a minimum of 3 inches. See illustration 2.

*NOTE: Trim Kit and microwave can only be built-in over an electric self-clean or non self-clean single cavity wall oven.

CABINET OR WALL CUTOUT

Cutout Dimensions(See illustration 3)

Height (A)		
Minimum	16 3/4"	(42.5 cm)
Maximum	17"	(43.2 cm)
Width (B)		
Minimum	24 3/4"	(62.9 cm)
Maximum	25"	(63.5 cm)
Depth (C)		
Minimum	20"	(50.8 cm)

IMPORTANT:

Before installing the exhaust duct, confirm the floor is level. The level bubble should be equal distance from level guide lines.

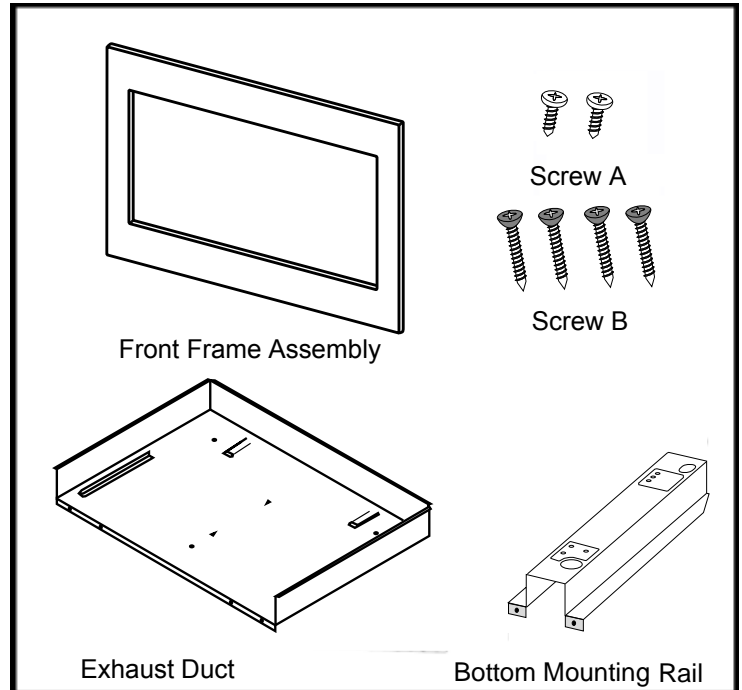

Illustration 1

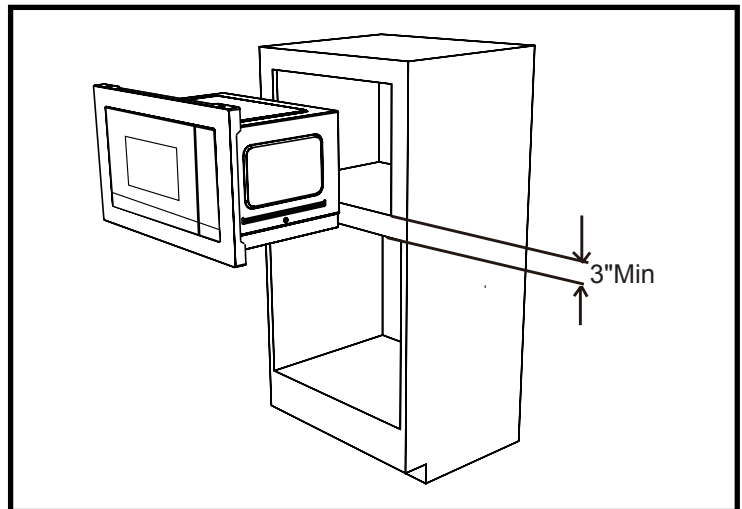

Illustration 2

Trim Kit Overall Dimensions		
	27"	30"
Height	18" (460.8mm)	18" (460.8mm)
Width	27" (685.8mm)	30" (759mm)
Depth	1 3/5" (40.9mm)	1 3/5" (40.9mm)

Installation Instructions

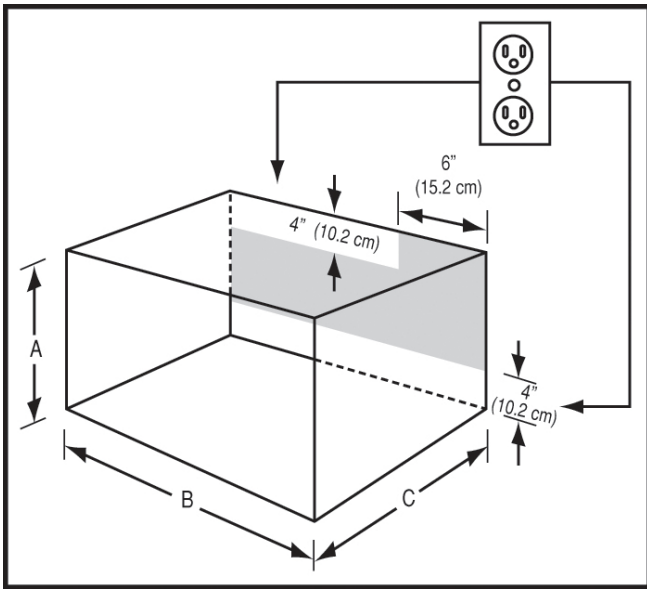

Illustration 3

ELECTRICAL OUTLET LOCATION

Outlet should NOT be in the shaded area as indicated on Illustration 3

NOTE 1:

The floor of the opening should be constructed of plywood strong enough to support the weight of the oven and floor load (approximately 100 pounds). The floor should be level for proper operation of the oven. Be sure to check the local building code as it may require that the opening be enclosed with side, ceiling and rear partition. The proper functioning of the oven does not require the enclosure.

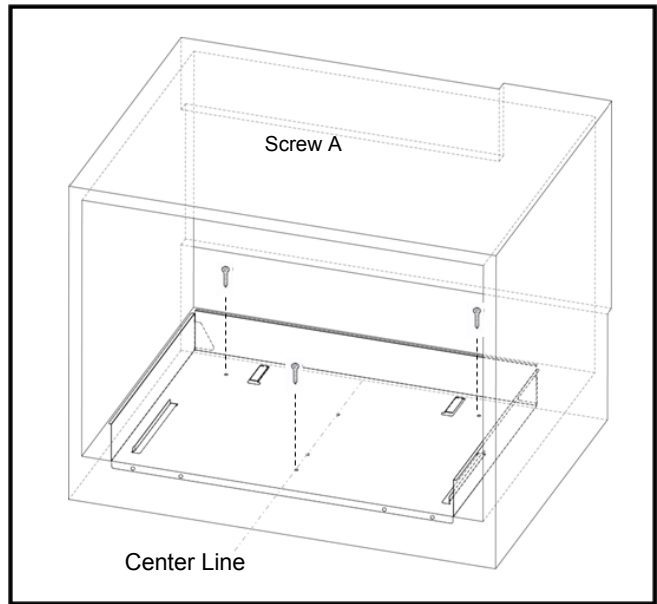

Illustration 4

EXHAUST DUCT ASSEMBLY

1. Draw a Central Line on floor. Place the Exhaust Duct in the opening. When the Exhaust Duct Assembly is in the opening correctly, the Center Line is in the middle of the Exhaust Duct Assembly. See Illustration 4.
2. Secure the Exhaust Duct Assembly with the three screws A.

IMPORTANT: Secure screws in outer hole. 3 pcs are needed for exhaust duct assembly

IMPORTANT:

Before installing the exhaust duct, confirm the floor is level. The level bubble should be equal distance from level guide lines.



Installation Instructions

Bottom Mounting Rail

Turn microwave upside down so you are looking at oven bottom. Secure the bottom Mounting Rail on oven with four SCREWS A. See Illustration 5.

NOTE: Please make sure to align the holes (marked with "36") of bottom mounting rail and the holes (marked with "36") of microwave oven's bottom plate.

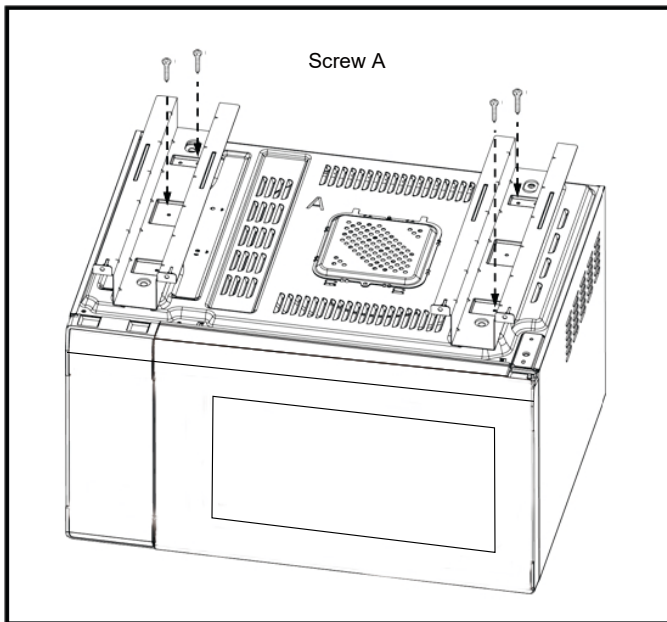

Illustration 5

OVEN INSTALLATION

1. Place the oven adjacent to the wall or cabinet opening. Plug the power cord into the electrical outlet.
2. Carefully guide the assembled oven into the prepared opening. Slide the oven on the Exhaust Duct Assembly. See Illustration 6.
3. Secure the Exhaust Duct Assembly with the four screws A.

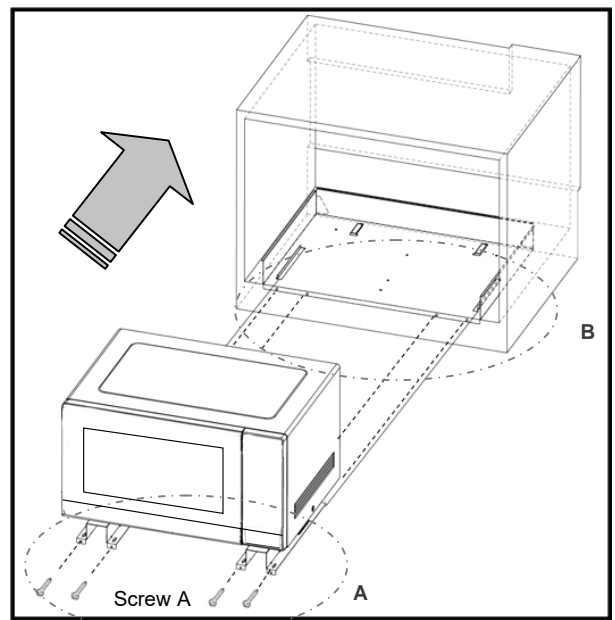
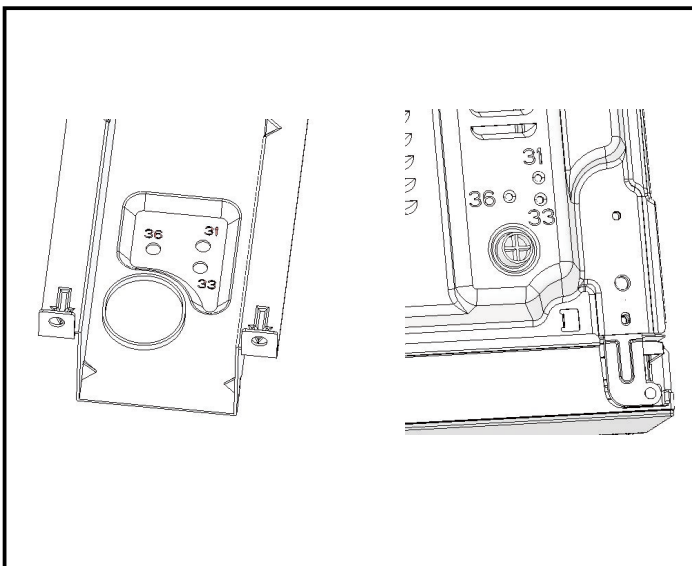

Illustration 6



Installation Instructions

FRAME INSTALLATION

1. Position the FRAME ASSEMBLY to be square with the oven. Carefully place the FRAME ASSEMBLY on the oven. See Illustration 7.
2. Check that it is level and then secure with two SCREWS B. Secure the bottom portion of the FRAME ASSEMBLY with the two remaining SCREWS B. See Illustration 8.

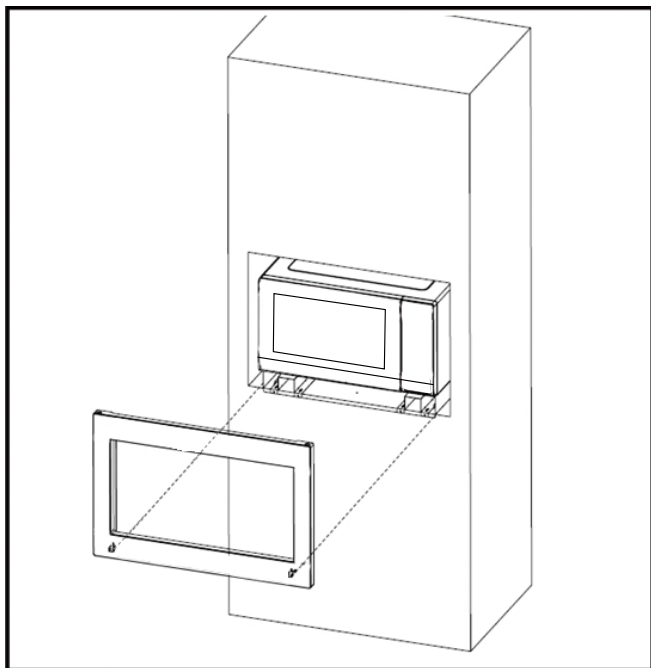

Illustration 7

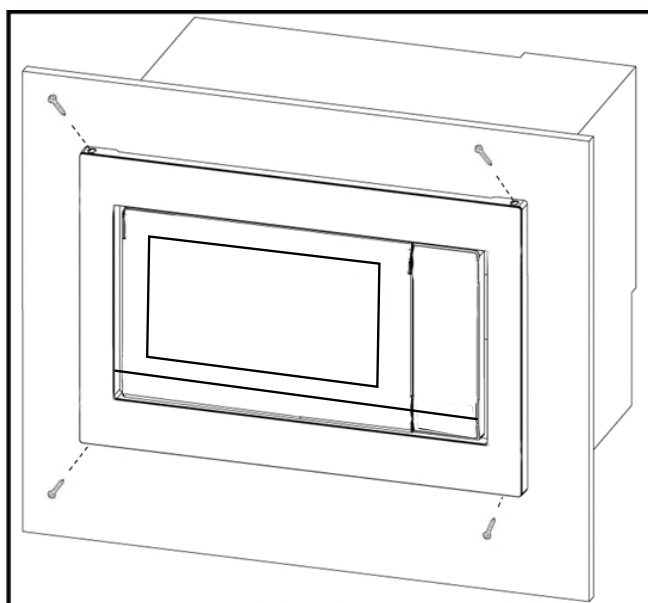

Illustration 8



SPEED QUEEN® MULTI-HOUSING LAUNDRY SOLUTIONS

Stack Washer/Dryer – Short

Quantum® Gold Pro

Prep for Card | Coin Drop Installed

Built for Reliable Performance

Speed Queen's stack washer/dryer brings an innovative stacked concept that takes up half the floor space that a conventional washer and dryer does when situated side by side. The freestanding softmount design can be installed on all floor types or levels. Both washer and dryer have the same hookups and connections as a standard washer and dryer. No additional plumbing or electrical change is needed. Speed Queen's stack washer/dryer combines heavy-duty construction with reliable operation proven to stand the test of time. They're designed with less moving parts for one reason: so you'll face fewer maintenance problems and less wear and tear down the road. Front load products have met every design standard to be 100% ADA compliant.

- Integrated meter case
 - Large capacity meter case standard
 - Wash Alert™ capability
- Washer (ADA Compliant)
- Rugged suspension system
 - Industry leading 1200 RPM spin speed exerts 440 G-force extraction
 - Durable stainless steel washtub
 - Four-compartment soap dispenser
 - Extra-wide 15.5" door opening and 180° door swing

- Dryer
- Upfront lint filter easy to clean
 - Industry's largest door opening 2.06 sq. ft. (1914 cm2)
 - Quiet, efficient blower system

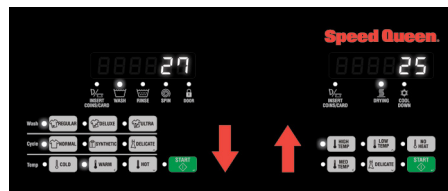

Quantum® Gold Pro Control

The Quantum® Gold Pro control delivers a truly premium experience to residents. From intuitive soft touch buttons that walk them through cycle options to multiple actuations (coin, card, mobile) for payment flexibility, this control gives residents the wash and dry options they want, and the revenue potential managers desire.

Stack Washer/Dryer – Short

Quantum® Gold Pro

Specifications	Washer	Dryer
Control Option	Quantum Gold Pro	
Color	White	
Capacity - lb (kg)	21.5 (9.5)	18 (8.2)
Overall Width - in (mm)	26.875 (683)	
Overall Depth - in (mm)	27.73 (704)	
Overall Height - in (mm)	76.5 (1943)	
Cylinder Volume cu. ft. (liters)	3.42 (96.8)	7.0 (198)
Motor Size - HP (kW)	0.9 (0.67)	
Type Of Gas (Gas Models Only)	-	Natural Gas
Water Consumption Per Cycle - g (liter)**	13.68 (51.78)	-
IWF (Water Factor) - gal/ft ³ (liters/liter/cycle)**	4.0 (0.53)	-
MEF ₁₂ (Modified Energy Factor) ft ³ /kWh/cycle (Liters/kWh/cycle)**	2.20 (62.3)	-
Available Water Temperatures	Hot, Warm, Cold	-
Available Cycles	Normal, Synthetic, Delicate	High, Medium, Low, Delicate, No Heat
Air Outlet Diameter - in (mm)	-	4 (102)
Exhaust Airflow - cfm (liters/sec)	-	220 (105)
Electrical Requirements	Electric	120/60/1-15 amp
	Gas	120/60/1-15 amp
Heating Element	Electric	-
	Gas	-
Net Weight - lb (kg)	385 (175)	
Shipping Weight - lb (kg)	417 (189)	
Shipping Dimensions Approx. - in (mm)	Width	34 (864)
	Depth	30 (762)
	Height	80 (2032)
Agency Approvals	Electric	cULus
	Gas	cCSAus

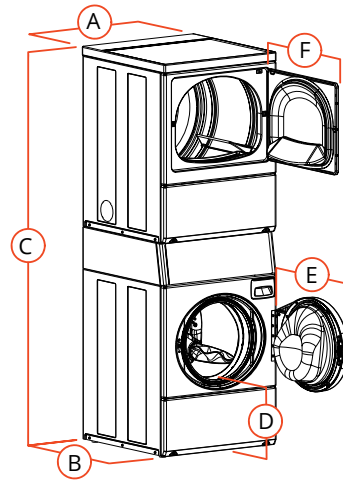

A. Overall Width - in (mm)	26.875 (683)
B. Overall Depth - in (mm)	27.73 (704)
C. Overall Height - in (mm)	76.5 (1943)
D. Floor To Door Opening - in (mm)	14.5 (368)*
E. Door Swing - in (mm)	23.5 (597)

* For ADA compliance turn legs out from base 0.5 inches

Models	Drain	Actuation
STENCFSP176TW01	Electric	Pump
STGNCFSP116TW01	Gas	Pump
STENYFSP176TW01	Electric	Pump
STGNYFSP116TW01	Gas	Pump



Electric dryers come equipped for 208-240/60/1 operation. They can be field converted to operate on 208/60/1 with optional 61928 conversion kit. Gas dryers can be field converted for operation on LP gas with optional 458P3 conversion kit.

** Average usage based on multiple load sizes and current DOE test protocol. Real usage will vary depending on load size, composition and cycle selectivity.

For the most accurate information, the installation guide should be used for all design and construction purposes. Due to continuous product improvements, design and specifications subject to change without notice. The quality management systems at Alliance Laundry Systems are registered to ISO 9001.

Commercial product is not authorized for sale to Residential end consumers.



SPEED QUEEN® MULTI-HOUSING LAUNDRY SOLUTIONS
Front Control Front Load Washer

Quantum® Gold Pro

Prep for Card | Coin Drop Installed

Built for Reliable Performance

Engineered and built like no other, the Speed Queen® front load washer is designed to be everything people thought a washer couldn't be, beginning with its revolutionary suspension and sensing technology. This groundbreaking innovation manages and redistributes out-of-balance loads to deliver uninterrupted cycles, virtually eliminate vibration and operate so quietly neighboring residents won't even know it's running. It also touts an incredible 440 G-Force extraction speed to maximize moisture removal, reduce dry times and minimize utility costs. And as if that's not game-changing enough, this smooth-running, laundry-optimizing machine delivers increased water efficiency. It's everything you never knew it could be. Front controlled products have met every design standard to be 100% ADA compliant.

- Revolutionary balancing technology
- Industry leading 1200 RPM spin speed exerts 440 G-force extraction
- Integrated meter case
- Extra-wide 15.5" door opening and 180° door swing
- Rugged suspension system
- Easy-to-read digital display
- Large capacity meter case standard
- Multi-level vend pricing
- Individual cycle modifier keys
- Durable stainless steel tub standard
- Four-compartment soap dispenser
- Wash Alert™ capability



Quantum® Gold Pro Control

The Quantum® Gold Pro control delivers a truly premium experience to residents. From intuitive soft touch buttons that walk them through cycle options to multiple actuations (coin, card, mobile) for payment flexibility, this control gives residents the wash and dry options they want, and the revenue potential managers desire.

Front Control Front Load Washer

Quantum® Gold Pro

Specifications		
Control Option	Quantum Gold Pro	
Color	White	
Capacity - lb (kg)	21.5 (9.5)	
Overall Width - in (mm)	26.875 (683)	
Overall Depth - in (mm)	27.73 (704)	
Overall Height - in (mm)	44.34 (1126)	
Cylinder Volume - cu. ft. (liters)	3.42 (96.8)	
Spin Speed G-Force (RPM)	440 (1200)	
Motor Size - HP (kw)	0.9 (0.67)	
Water Consumption Per Cycle - g (liter)**	13.68 (51.8)	
IWF (Water Factor) - gal/ft ³ (liters/liter/cycle)**	4.0 (0.53)	
MEF _{j2} (Modified Energy Factor) ft ³ /kWh/cycle (Liters/kWh/cycle)**	2.20 (62.3)	
Available Water Temperatures	Cold, Warm, Hot	
Available Cycles	Normal, Synthetic, Delicate	
Electrical Requirements (v/Hz/Ph-Amp)	120/60/1 - 15 Amp	
Water Pressure - p.s.i. (bar)	20-120 (1.4/8.3)	
Cylinder Finish	Stainless Steel	
Net Weight - lb (kg)	260 (118)	
Shipping Weight - lb (kg)	270 (122.5)	
Shipping Dimensions Approx. - in (mm)	Width	34 (864)
	Depth	30 (762)
	Height	44.5 (1130)
Agency Approvals	cULus	

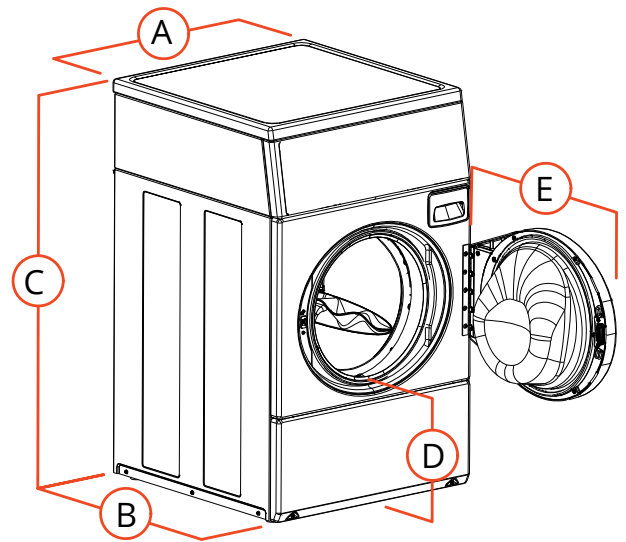

A. Overall Width - in (mm)	26.875 (683)
B. Overall Depth - in (mm)	27.73 (704)
C. Overall Height - in (mm)	44.34 (1126)
D. Floor To Door Opening -in (mm)	14.6 (371)*
E. Door Swing - in (mm)	24 (610)

* For ADA compliance turn legs out from base 0.5 inches

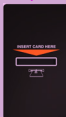
Models	Drain	Actuation
SFNNCASP116TW01	Pump	Coin Drop Installed 
SFNNCASG116TW01	Gravity	
SFNNYASP116TW01	Pump	Prep for Card 
SFNNYASG116TW01	Gravity	

Supply inject kits available.

** Average usage based on multiple load sizes and current DOE test protocol. Real usage will vary depending on load size, composition and cycle selectivity.

For the most accurate information, the installation guide should be used for all design and construction purposes. Due to continuous product improvements, design and specifications subject to change without notice. The quality management systems at Alliance Laundry Systems are registered to ISO 9001.



SPEED QUEEN® MULTI-HOUSING LAUNDRY SOLUTIONS

Stack Dryer – Solid Door

Quantum® Gold Pro

Prep for Card | Coin Drop Installed | Prep for Coin

Built for Reliable Performance

Speed Queen's stack dryer offers the same great features as the single load dryer. Two commercial dryers in the space of one, both operating independently, including independent controls for optimum usage. Defined by its simplicity and its performance, Speed Queen provides everything you need to get the job done - and nothing you don't. Speed Queen's stack dryer combines heavy-duty construction with reliable operation proven to stand the test of time. They're designed with less moving parts for one reason: so you'll face fewer maintenance problems and less wear and tear down the road. Speed Queen's dryers provide the perfect balance of heat, airflow and tumble action for optimal performance and efficiency. Bottom dryer is ADA compliant.

- Integrated meter case
- Industry's largest door opening 2.06 sq. ft. (1914 cm²)
- Quiet, efficient blower system
- High efficiency exhaust blower with superior airflow 220 cfm (105 liters/sec)
- 100% serviceable from the front
- Space-saving narrow cabinet 26.875" (683 mm)
- Upfront lint filter easy to clean and secured
- Durable galvanized steel cylinder
- Large capacity meter case standard

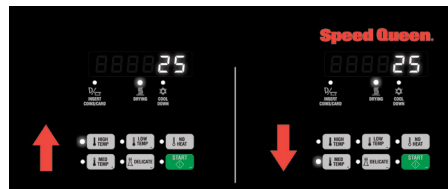



Quantum® Gold Pro Control

The Quantum® Gold Pro control delivers a truly premium experience to residents. From intuitive soft touch buttons that walk them through cycle options to multiple actuations (coin, card, mobile) for payment flexibility, this control gives residents the wash and dry options they want, and the revenue potential managers desire.

Stack Dryer – Solid Door

Quantum® Gold Pro

Specifications		
Control Option		Quantum Gold Pro
Color		White
Capacity - lb (kg)		18 (8.2) ea
Overall Width - in (mm)		26.875 (683)
Overall Depth - in (mm)		28 (711)
Overall Height - in (mm)		78.17 (1986)
Cylinder Volume - cu. ft. (liters)		7.0 (198) ea
Motor (Thermal Protected)		0.33 HP
Type Of Gas (Gas Models Only)		Factory Equipped Natural
Air Outlet Diameter - in (mm)		4 (102)
Exhaust Airflow - cfm (liters/sec)		220 (105)
Available Cycles		High, Medium, Low, Delicates, No Heat
Electrical Requirements	Electric	208-240/60/1-30 amp
	Gas	120/60/1-15 amp
Heating Element	Electric	5350W, 240V 4750W, 208V
	Gas	25,000 Btu
Shipping Dimensions Approx. - in (mm)	Width	33 (838)
	Depth	30 (762)
	Height	80 (2032)
Net Weight - lb (kg)	Electric	270 (122)
	Gas	270 (122)
Shipping Weight - lb (kg)	Electric	280 (127)
	Gas	280 (127)
Agency Approvals	Electric	cULus
	Gas	cCSAus

Models	Voltage/Freq/PH	Actuation	
SSENCAGS176TW01	208-240/60/1	Electric	Coin Drop Installed 
SSGNCAGS116TW01	120/60/1	Gas	
SSENXAGS176TW01	208-240/60/1	Electric	Prep for Coin 
SSGNXAGS116TW01	120/60/1	Gas	
SSENYAGS176TW01	208-240/60/1	Electric	Prep for Card 
SSGNYAGS116TW01	120/60/1	Gas	

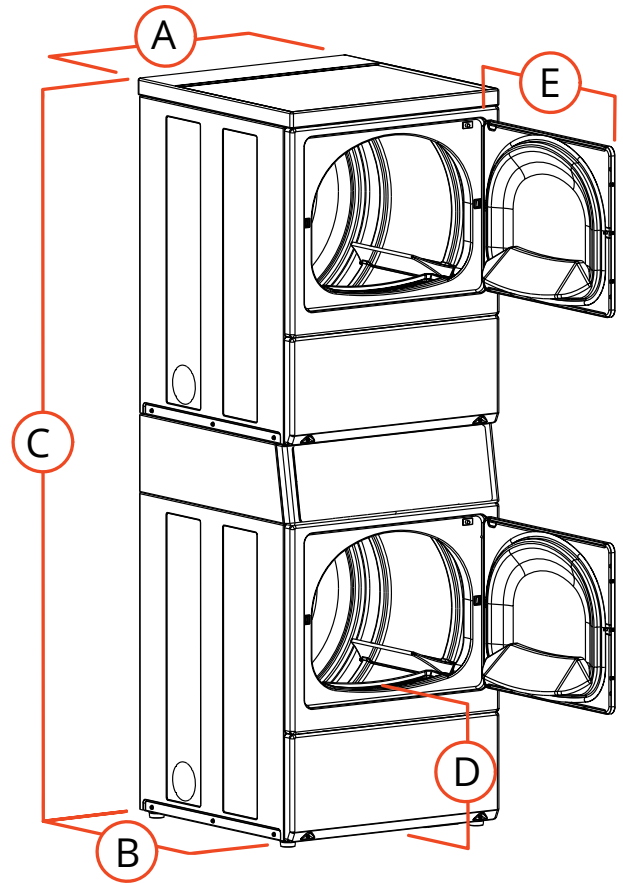

A. Overall Width - in (mm)	26.875 (683)
B. Overall Depth - in (mm)	28 (711)
C. Overall Height - in (mm)	78.17 (1986)
D. Floor To Door Opening - in (mm)	15.44 (392)
E. Door Swing - in (mm)	23.5 (597)

NOTE: Each stack dryer pocket requires its own separate power cord (not supplied).

Electric dryers come equipped for 208-240/60/1 operation. They can be field converted to operate on 208/60/1 with optional 61928 conversion kit.

Gas dryers can be field converted for operation on LP gas with optional 458P3 conversion kit.

For the most accurate information, the installation guide should be used for all design and construction purposes. Due to continuous product improvements, design and specifications subject to change without notice. The quality management systems at Alliance Laundry Systems are registered to ISO 9001.

Commercial product is not authorized for sale to Residential end consumers.

1 ELIM08A	2 ELIM10A	3 ELIK11A-PC POW+ETH	4 ELIM16A
--------------	--------------	----------------------------	--------------

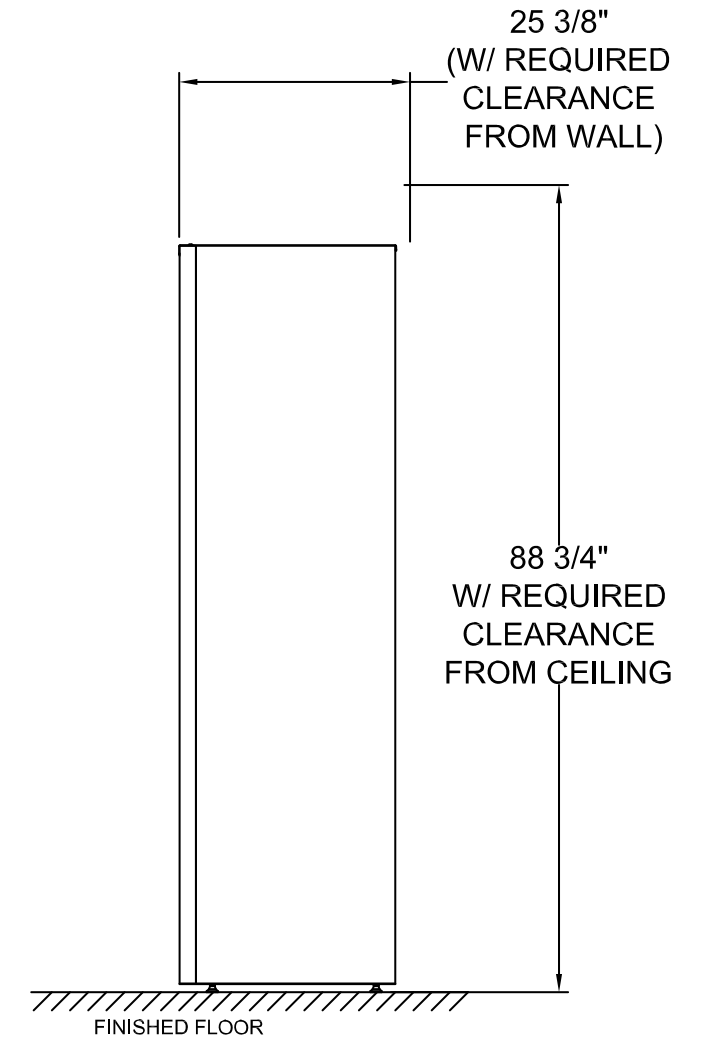
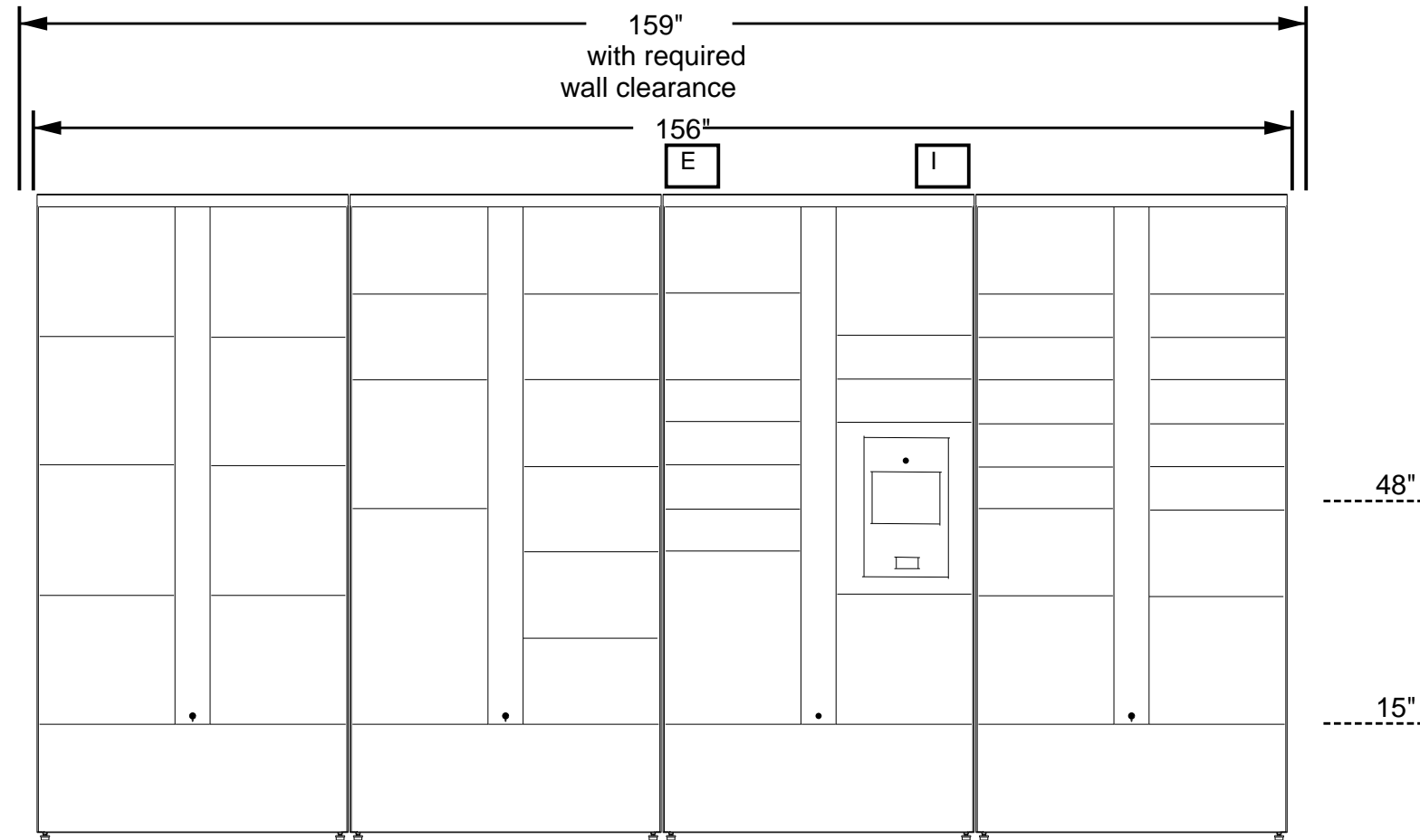

System Overview

- Locker Series:** Element Indoor
- Installation Type:** Linear
- Color Finish:** tbd
- Total Package Lockers:** 45
- Total Dry Cleaning Lockers:** 0

Site Preparation Requirements (Provided by Others):

- Electrical and Internet outlets must be installed with bottom of the faceplates at 83" FFF. If outlets are surface mounted, bottom of faceplates must be at 84.5" FFF.
- System dimensions shown above should be verified in the field to confirm the system fits within the desired space
- Each locker module has a typical dimension tolerance of +/- 1/8"
- Actual Locker Height is: 82-1/4" - 83-3/4" (range due to adjustable leveling feet)
- Actual Locker Depth is: 23-7/8"
- If the system will be recessed and trimmed in, all finished trim must be completed after installation

Module/Tower Count	
Module	Qty.
ELIM04A	0
ELIM08A	1
ELIM09A	0
ELIM10A	1
ELIM13A	0
ELIM16A	1
ELIK11A-PC	1
ELIM04A-DCL	0
Total:	4

Locker Compartment Information (inches)				
Type	Qty.	Height	Width	Depth
1-High	16	4.8	13.5	22.5
2-High	14	10.3		
3-High	13	15.8		
4-High	1	21.3		
5-High	1	26.8		
6-High	0	32.3		
D6-High	0	32.3		
Total:	45			

DO NOT SCALE OFF THIS DRAWING

ELEVATION: Front View / Profile Bank 1	
ARCHITECT: HPI Architects	
PROJECT NAME: Compton Student Housing	DRAWN BY: Vivian Teeter
CREATED: 02/23/2023	LOCATION: Compton ,CA
INSTALL BY: 2025	REFERENCE NO:
DRAWING NO. WEB-16133	SHEET 1
APPROVED SIGNATURE:	PRINTED NAME/DATE:

PACKAGE CONCIERGE

packageconcierge.com

Manufactured by Florence Corporation

versatile™ 4C Mailbox, 4C10D-18

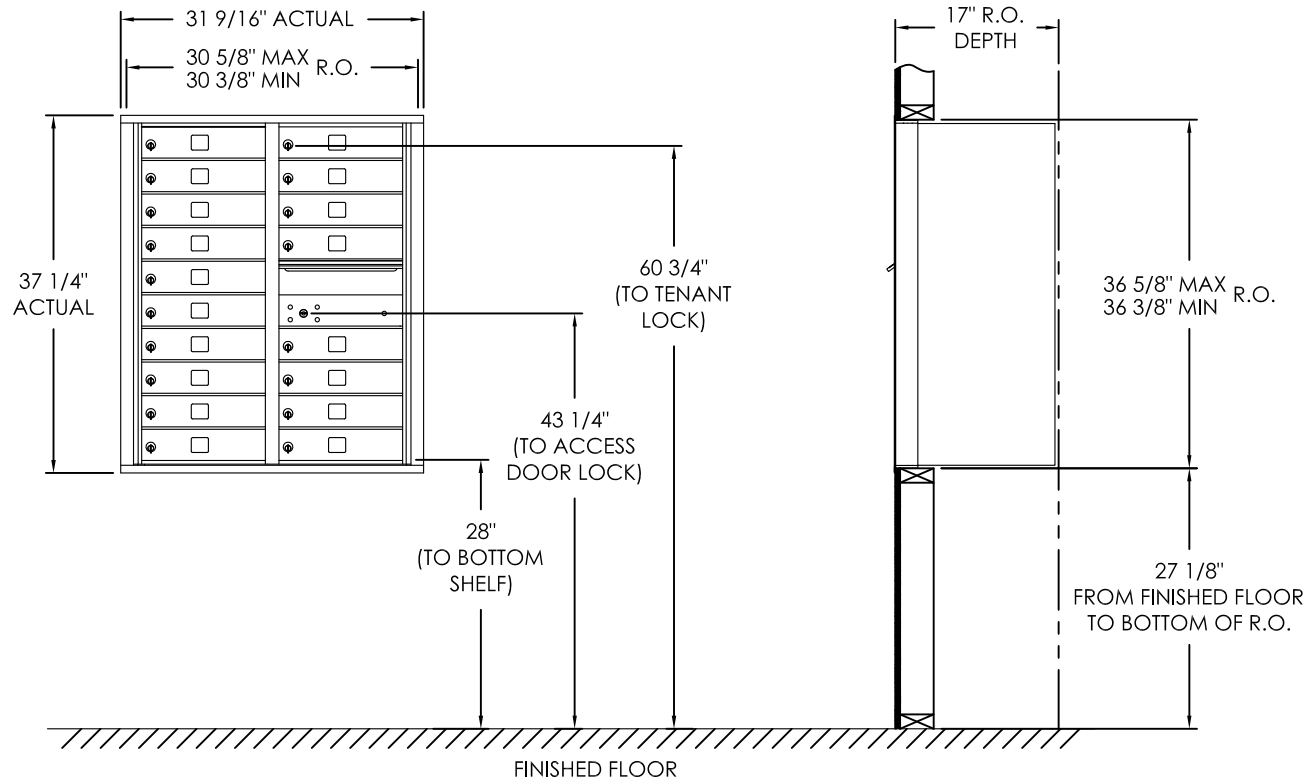

COMPARTMENT CHART

DESCRIPTION	COMPARTMENT	COMPARTMENT SIZE	QTY.
MAILBOX	MB1	3" H x 12" W x 15" D	18
OUTGOING MAIL	OM2	6-1/2" H x 12" W x 15" D	1

Notes:

- This module meets the USPS STD-4C requirements for installation defined below when the mailbox is installed per the dimensions provided on this drawing.
 - At least one customer compartment shall be positioned less than 48" above finished floor (AFF).
 - No parcel locker (interior bottom shelf) shall be positioned less than 15" AFF.
 - No patron (tenant) lock shall be positioned more than 67" AFF.
 - No customer compartment (interior bottom shelf) shall be positioned less than 28" AFF.
 - The USPS Arrow lock shall be positioned 36"- 48" AFF.
- This 4C mailbox can also be used for private applications.
- The rough opening width for multi-unit 4C installations is provided using the Florence configurator: www.florencemailboxes.com/configurator.

PRODUCT SERIES: VERSATILE™ 4C FRONT LOAD MAILBOX

FLORENCE
CORPORATION

5935 Corporate Drive • Manhattan, KS 66503
800.275.1747 • www.florencemailboxes.com

MODEL	4C10D-18	REV	C
SCALE	NONE	LAST REV DATE	06/27/19
DRAWING NUMBER	4C10D-18CS	DRAWN BY	RAK